

**REMA YAM ratchet hoist**

The REMA YAM mini ratchet hoist is compact and a very low own weight. The required manual effort on the short handle (180 mm) remains low because the YAM is equipped with a gear transmission. The ideal tool for assembly work such as hoisting, pulling and tensioning.

**Properties:**

- Very low self weight (2,8 kg), compact.
- Hooks equipped with safety latches.
- Self locked brake holds the load at any desired height.
- Freewheel is possible in unloaded condition, by 1 operation.
- Hoist fitted with rubber anti-slip handle.
- In case of overload, the hooks will gradually bend and do not suddenly break off.
- Galvanized load chain Grade 10.

**Standard delivery:**

- 1,5 m lifting height (max. distance between top & bottom hooks).

**Option:**

- Available in other lifting heights.

**Norm:**

- EN12100-1/2, EN13157, EN818-7



**Only weighs 2,8 kg with 1,5 meter Lifting**

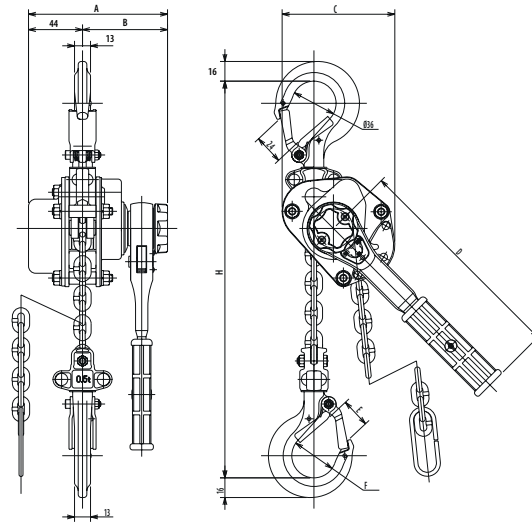

Type	WLL (kg)	Hand force max. (kg)	Load chain (mm)	Number of falls	Construction height (mm)	Weight (kg)	productid
YAM-500KG	500	35	4.3 x 12	1	240	2.8	0208002

Type	A (mm)	B (mm)	C (mm)	D (mm)	E (mm)	F (mm)	H (mm)
YAM-500KG	113	69	92	180	24	36	240